

MUVE DESIGN

NARDIN PIETRO

**I.S.S ABATE ZANETTI
MURANO**

A.S 2021 / 2022

MUVE.D

PRESENTAZIONE PROGETTO

Si era proposto di elaborare un progetto indirizzato ai musei civici di Venezia che potesse avere come protagonista il vetro di Murano. Il nome di questo progetto è Muve Design, e il tema riguardante tutto ciò è legato al Santo Patrono di tutti i maestri vetrai di Murano il quale si festeggia il 6 Dicembre.

Il nome di questo Santo è San Nicolò.

L'idea di questo progetto è partita con l'osservazione della parte superiore del ferro di prua delle Gondole per poi elaborarla inserendo linee e colori che ricordano il paesaggio lagunare veneziano.

I colori utilizzati sono colori dai toni caldi e rilassanti poiché vanno tutti dal Giallo all'Arancio ed infine al Rosso. Le misure sono 31 x 33 x 11,5 cm che sono base, altezza, profondità.

Il colore della scultura è Cristallo Trasparente con i fili di vetro all'interno disposti in modo sparso dei colori del Tramonto e dell'Alba.

PRESENTATION PROJECT

It was proposed to develop a project addressed to the museums of Venice that could have Murano glass as its protagonist. The name of this project is Muve Design, and the theme versional all what is related get Saint Patron of all the masters ventral of Murano the which it fester the six December. The name of this Saint is San Nicolò.

The idea of this project is shutout with the observation of the superior part the iron about fore of the Condoles for then elaborate inference sketch and colors that recording the scenery venetian wash.

The colors utilization are colors put toned hot and relaxed because go all get Yellow ,Orange and the Red. The measure are 31 for 33 for 11,5 centimetre that

The color of the sculpture is Crystal Trasparent with wirelles the glass inside snake fence in way broadcast do colors get Sundown and get Dawn.

RIFERIMENTI
E RELAZIONE

COPERTINA

BOZZE / ROUGH

DEFINITIVI

MOODBOARD

TAVOLA 2D E 3D

VENEZIA / MURANO

COLORI

TIPI DI VETRO
E TECNICHE.

REFERENCES RELATION

ROUGH

DEFINITIVE

MOODBOARD

VENICE AND MURANO

COLORS

LINER

TYPE ABOUT GLASS AND TECHNO

ITALIANO

INGLESE

BOZZE

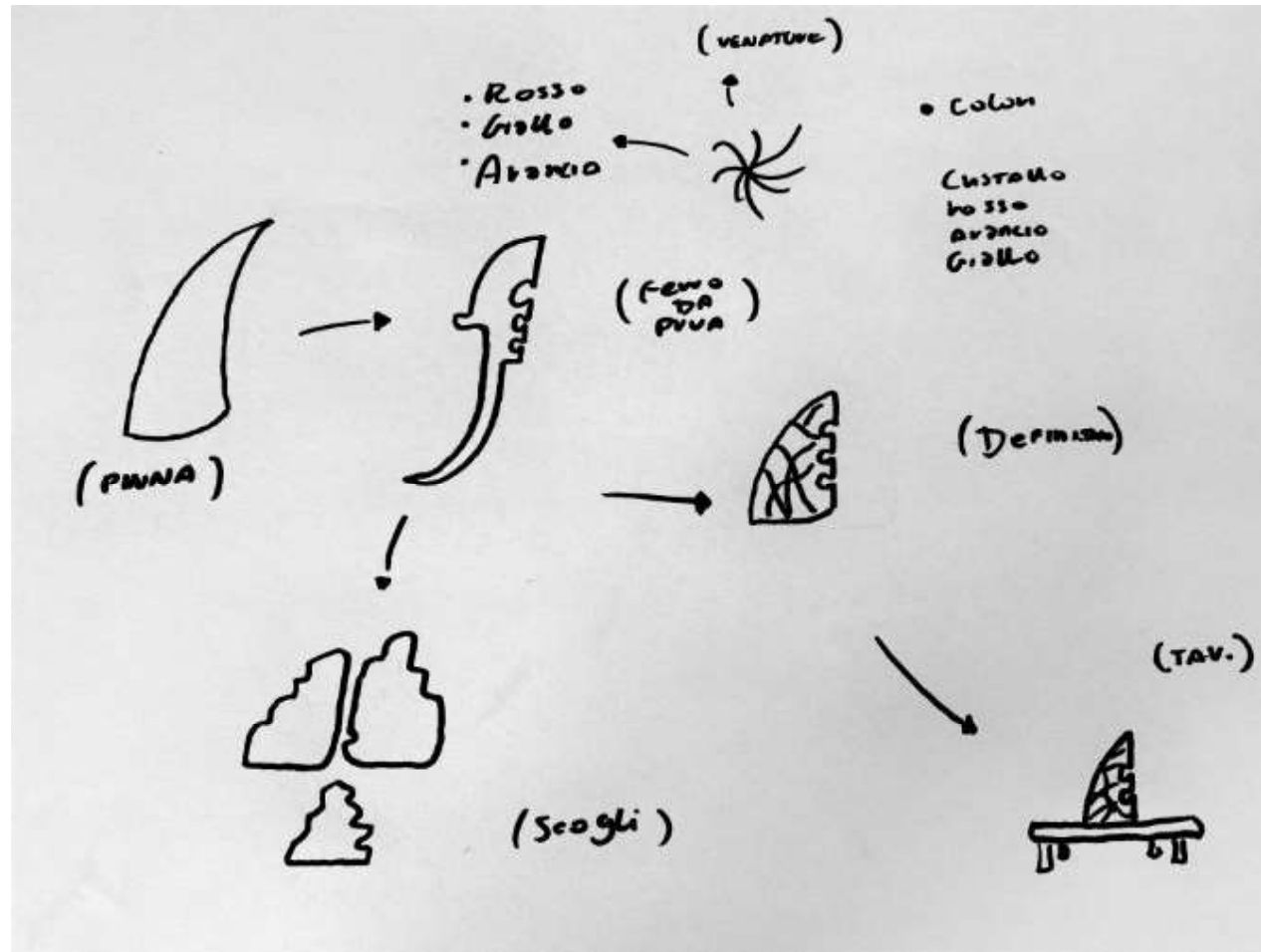

M
O
O
D
B
O
A
R
D

fornacemian
murano



MURANO VENEZIA ISTITUTO TECNICO TECNOLOGICO
ABATEZANETTI INDIRIZZO GRAFICA E COMUNICAZIONE
ISTITUTO SCOLASTICO SUPERIORE PARITARIO CON POTENZIAMENTO DELL'OFFERTA
FORMATIVA IN ARTE DEL VETRO

ARANCIO



GIALLO LIMONE
CHIARO



CORALLITE



GIALLO LIMONE
MEDIO



ROSSO



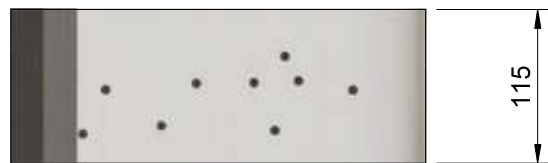
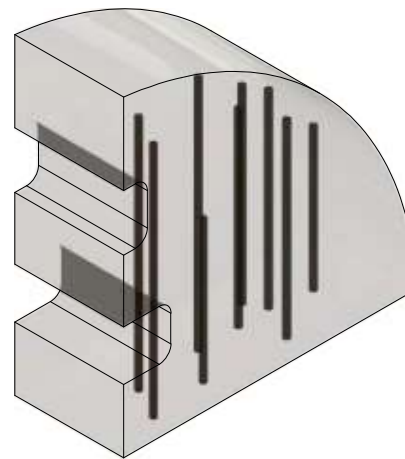
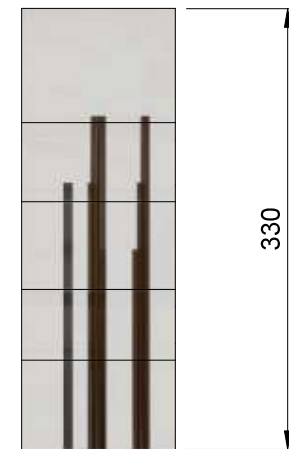
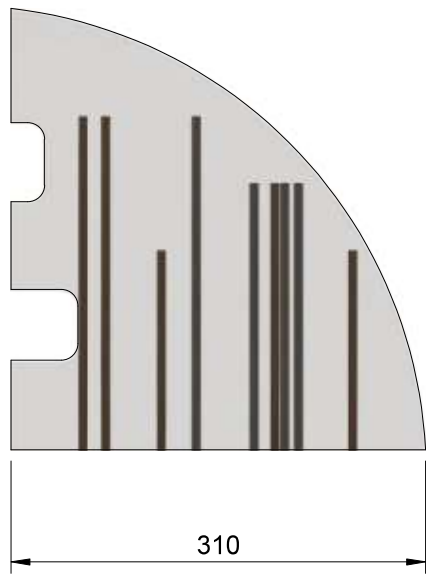

Dept. 1	Technical reference Grafica	Created by Pietro Nardin 7/12/2021	Approved by	
		Document type	Document status	
		Title San Nicolò	DWG No. Tav 1	
		Rev.	Date of issue	Sheet 1/1

RENDERING

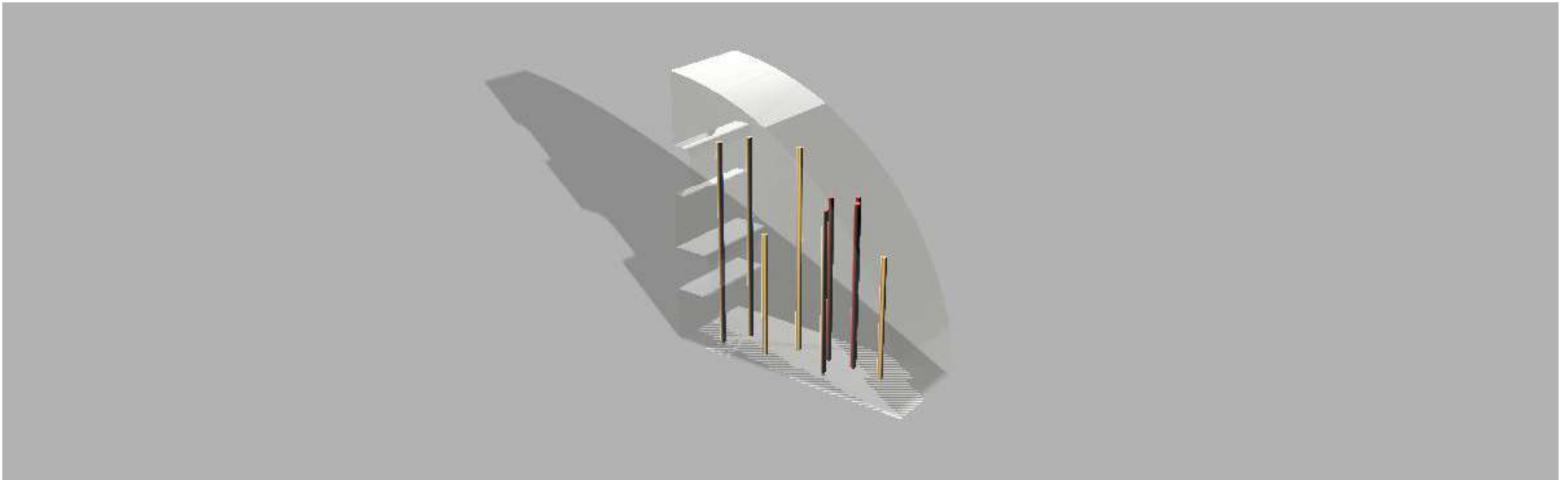

RIFERIMENTI

MUSEI CIVICI DI VENEZIA MUVE



FORNACE MIAN MURANO (VE)

I.S.S ABATE ZANETTI MURANO (VE)



fornacemian
murano



THE END

3M6F